

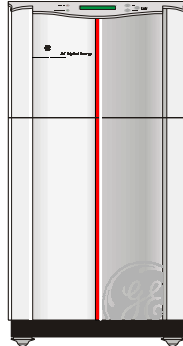

**GE Digital Energy**



**OPERATING MANUAL**  
**UNINTERRUPTIBLE POWER SUPPLY**

***LanPro 11***

**3-5-6-8-10 kVA**

Manufactured by:

**GE Digital Energy**  
General Electric Company  
CH - 6595 Riazzino (Locarno)  
Switzerland

Telephone +41 (0)91 / 850 51 51  
Fax +41 (0)91 / 850 51 44  
Website [www.gedigitalenergy.com](http://www.gedigitalenergy.com)



**LanPro UPS**

***Technology for the Digital World.***

*ver 2.0 - GB*



**OPERATING MANUAL**  
**UNINTERRUPTIBLE POWER SUPPLY**

***LanPro 11***

**3-5-6-8-10 kVA**

**Preface**

We thank you for selecting a **GE (General Electric) Digital Energy** Uninterruptible Power Supply (UPS) and recommend that you read these instructions carefully before installation and start-up of the **LanPro** UPS.

Please keep this manual in a safe place for future reference and carefully read the important safety instructions in chapter 1 before installation of this device.



CONTENTS

1 IMPORTANT SAFETY INSTRUCTIONS .....3  
1.1 Save these instructions  
1.2 General  
1.3 Installation  
1.4 Storage  
1.5 Batteries

2 INTRODUCTION .....4

3 FUNCTIONAL EXPLANATION.....5  
3.1 Principles of Operation  
3.2 Normal Conditions  
3.3 Utility Failure  
3.4 Automatic Bypass Switch  
3.5 Manual Bypass Switch

4 INSTALLATION .....7  
4.1 Unpacking  
4.2 Package Contents  
4.3 Location  
4.4 Installation  
4.4.1 LanPro 3/5/6-11: standard installation procedure  
4.4.2 LanPro 3/5/6-11: installation of GE Digital Energy LanPro battery extension pack(s)  
4.4.3 LanPro 8/10-11: standard installation procedure  
4.4.4 LanPro 8/10-11: installation of GE Digital Energy LanPro battery extension pack(s)  
4.4.5 LanPro-11 series: 2 / 3 / 4 parallel operating units – additional info

5 OPERATION ..... 15  
5.1 Description of Front and Rear Panel  
5.2 Start-up  
5.3 Use  
5.3.1 Information menu  
5.3.2 Status and alarm menu  
5.3.3 Service menu  
5.3.4 Setup menu  
5.4 Test Screens  
5.4.1 Battery test, general  
5.4.2 Quick battery test  
5.4.3 Deep battery test  
5.5 Other Features  
5.5.1 Shutdown  
5.5.2 Mains start  
5.5.3 Sleep and wake-up  
5.5.4 Overload protection in bypass mode  
5.5.5 ECO-Mode  
5.5.6 Auto restart  
5.5.7 Superior battery management

6 INTERFACING FEATURES .....28  
6.1 RS232/Contact Interface  
6.2 Emergency Shutdown  
6.3 Relay Card (optional)  
6.4 SNMP Interface (optional)

7 OPTIONAL FEATURES.....29  
7.1 Extended Runtime Versions  
7.2 Plug-in Cards  
7.3 RPA-Facility (Redundant Parallel Architecture)

8 MAINTENANCE .....30  
8.1 General  
8.2 Cooling fan  
8.3 Batteries  
8.4 Safety  
8.5 Storage

9 TROUBLESHOOTING .....31

10 SPECIFICATIONS .....32

APPENDIX: INSTALLATION DRAWINGS



# 1 - Important Safety Instructions

## 1.1 Save these instructions

This manual contains important instructions that should be followed during installation and maintenance of the UPS.



Before attempting to install and start up the UPS, carefully read this manual. Keep this manual next to the UPS for future references. All servicing must be done by qualified personnel. Do not attempt to service the UPS unless you have had proper training.

**CAUTION:** By opening or removing covers you run the risk of exposure to dangerous voltages!



While every care has been taken to ensure the completeness and accuracy of this manual, **GE Digital Energy** accepts no responsibility or liability for any loss or damage resulting from the use of the information contained in this document.

This document shall not be copied nor reproduced without the permission of **GE Digital Energy**.

Due to technical improvements, some of the information contained in this manual may be changed without notice.

## 1.2 General

- **CAUTION: RISK OF ELECTRIC SHOCK** Do not remove the cover, there are no user serviceable parts inside. All maintenance and service work should be performed by qualified service personnel. The UPS contains batteries. The appliance outlet may be electrically live, even when the UPS is disconnected from the utility supply. Dangerous voltages may be present during battery operation. The batteries must be disconnected during maintenance or service work.
- The UPS contains potentially hazardous voltages.

## 1.3 Installation

- This UPS is intended to be used in a controlled environment indoors and free of conductive contaminants.
- The UPS should only be powered from a single phase, three wire AC source equipped with an earth connection.
- Do not install the UPS in an excessively humid environment or near water.
- Avoid getting liquids or any foreign object into the UPS.
- The unit must be placed in a sufficiently ventilated area; the ambient temperature should not exceed 40°C. Optimal battery lifetime is obtained if the ambient temperature does not exceed 30°C.
- It is important that the unit has adequate ventilation. Maintain air movement around and through the unit. Do not block the air vents.
- Avoid placing the unit in direct sunlight or near heat sources.
- Do not plug household appliances such as electric heaters, toasters or vacuum cleaners into the UPS.

## 1.4 Storage

- Store the UPS with its batteries fully charged in a dry location, storage temperature must be within -20 and +45°C.  
If the unit is stored for an extended period of time, the batteries must be recharged periodically. Connect the unit to the mains and switch it on:
  - if the storage temperature is within -20 and +30°C, recharge the batteries every 3 months, for 24 hours,
  - if the storage temperature is within -20 and +45°C, recharge the batteries every month, for 24 hours.

## 1.5 Batteries

- **NOTE:** All maintenance and service work, including battery replacement, should be performed by qualified service personnel.
- When replacing the batteries, use only the same type and size battery.
- Proper disposal or recycling of the batteries is required. Refer to your local codes for disposal requirements.
- Never dispose of batteries in a fire: they may explode.
- Do not open or mutilate batteries: their contents may be extremely toxic. If exposed to electrolyte, wash immediately with plenty of water.
- Avoid charging in a sealed container.
- Never short circuit batteries. When working with batteries, remove watches, rings or other metal objects, and use only insulated tools.



## 2 - Introduction

More than ever before, today's advanced electronic equipment, with complex integrated circuits and other sensitive electronics, needs a stable and continuous AC power supply to operate correctly. While the power coming from the wall outlet is often unreliable, a **GE Digital Energy LanPro UPS** provides the security of completely uninterrupted power.

A compact, truly on-line system, the **GE Digital Energy LanPro UPS** protects your equipment from all forms of power interference, including complete power failure. A simple and elegant circuit design, together with extensive protection against abnormal operating conditions (e.g. overload, short circuit, overheating), makes the **LanPro** exceptionally reliable.

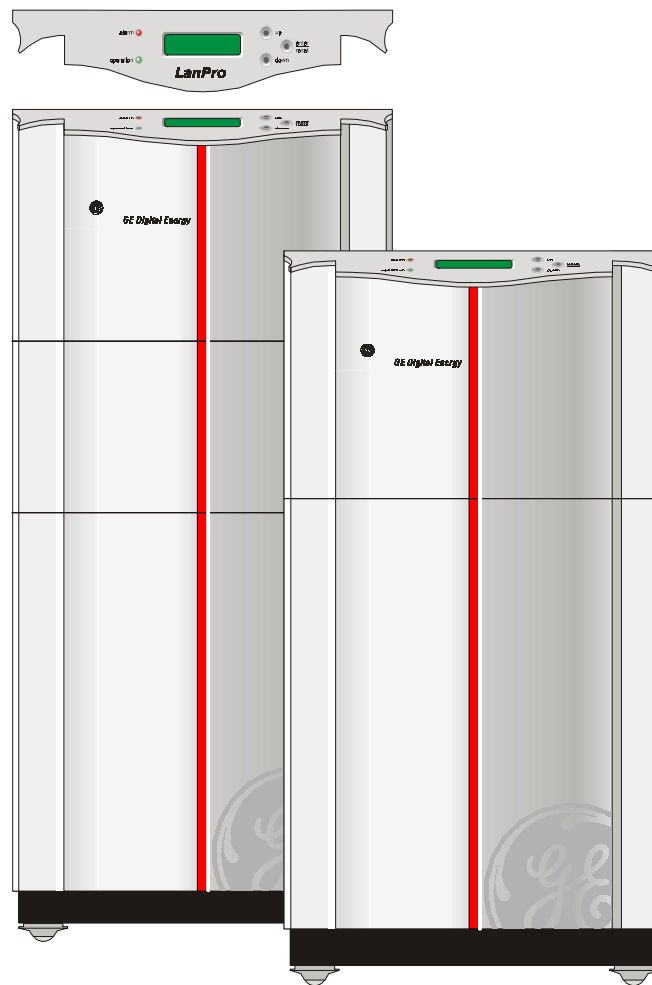

Figure 1. The **GE Digital Energy LanPro-11 UPS**: 3/5/6-11 (front) and 8/10-11 (rear)



## 3 - Functional Explanation

### 3.1 The Principles of Operation

The **LanPro** UPS stores electric energy in batteries. This allows the UPS to supply output power even when the incoming utility power is cut off completely. Energy is stored as Direct Current (DC), while input and output energy must be Alternating Current (AC). Therefore the UPS contains an input converter (AC to DC) and an output converter (DC to AC). (fig.2)

### 3.2 Normal Conditions

Under normal conditions, energy from the utility is channelled through the input converter, which supplies the output converter and the battery charger. The batteries are kept in a fully charged state, and the output converter synthesizes a completely new AC output sine wave to supply the load (electrical equipment).

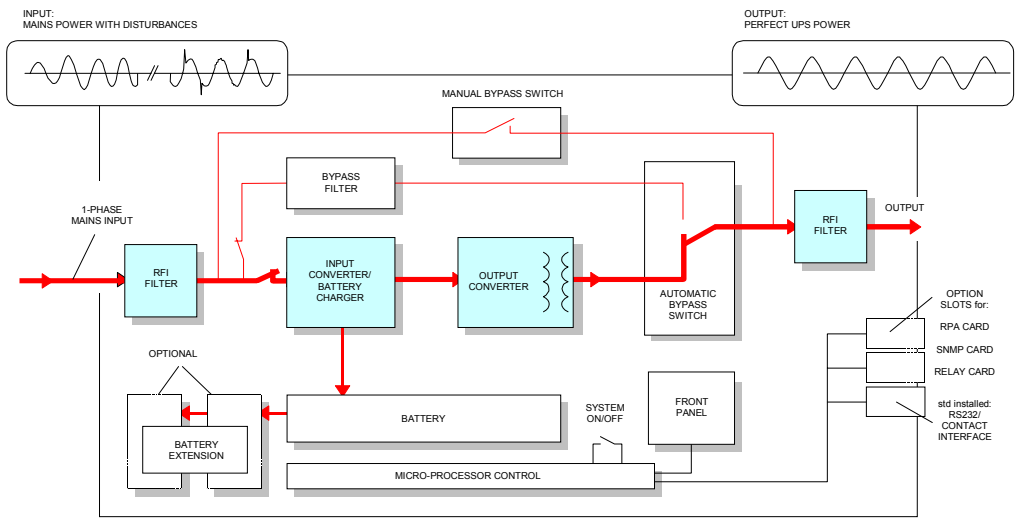

Figure 2. Block diagram of the LanPro-11 UPS, mains present

### 3.3 Utility Failure

In the event of a utility power failure (i.e. absent or outside tolerance) the system uses the energy reserve stored in the battery to continue to produce AC power, ensuring unbroken output (fig. 3). No interruption or alteration will ever be noticed in the output power.

In the event of an extended utility failure, the output converter will stop when the battery has been discharged. At this point, the UPS is no longer able to power the connected equipment.

When the utility is re-established within tolerance, the output converter will restart automatically (if stopped, see above) and will be supplied again by the input converter. The batteries will be recharged, making them ready to support future power failures.

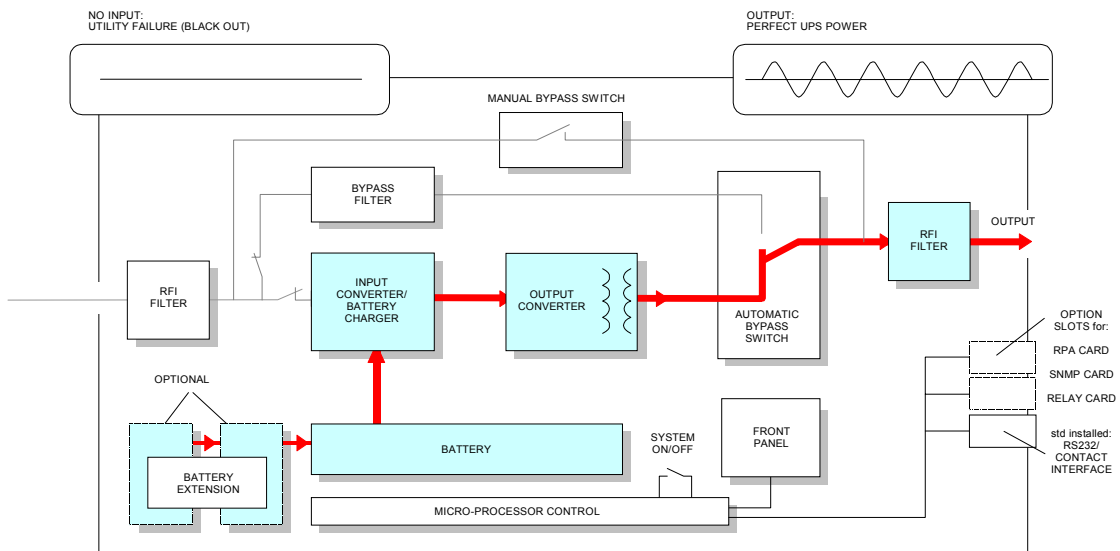

Figure 3. Block diagram of the LanPro-11 UPS, utility failure



### 3.4 Automatic Bypass Switch

If the output converter is unable to deliver the demanded output power because of overload or overtemperature, the automatic bypass switch will automatically transfer the load to the utility. When the situation is corrected the UPS will switch back to normal operation, i.e. the load is transferred back to the output converter. Though the automatic bypass switch is shown as a simple mechanical switch in figures 2-5, the transfers are done by means of thyristors, i.e. electronically, without any interruption of the power supplied to the load.

In case of a severe overload or short-circuit the magnetic bypass circuit breaker (rear panel) may trip in order to protect the UPS. If the current is insufficiently high to trip the breaker, the UPS will be switched off by the software in order to protect the UPS and connected equipment.

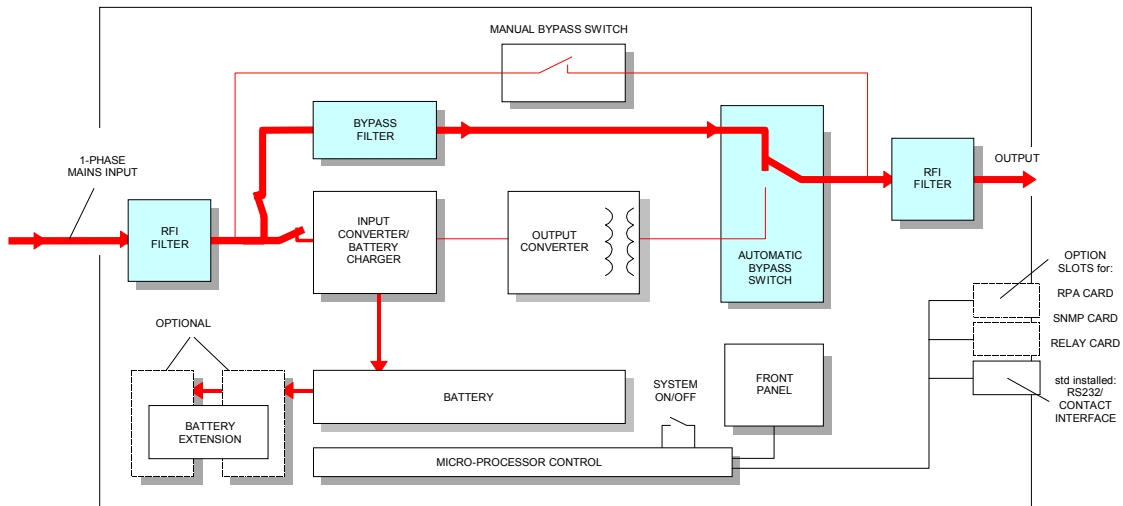

Figure 4. Bypass operation: automatic bypass

If a power failure occurs during bypass operation, load power is lost. If the UPS functions under overload conditions it may not be able to protect the load.

### 3.5 Manual Bypass Switch (Service switch)

The system can be bypassed manually using the manual bypass switch located at the rear panel. It is a two-position switch: the normal position is '1': as in figures 2-4. Position '2' is the service position: the load is directly connected to the utility input. This way maintenance of the UPS (e.g. battery replacement, as in fig. 5) is possible without interruption of the power supplied to the load.

**CAUTION: REFER SERVICE TO QUALIFIED PERSONNEL ONLY.**

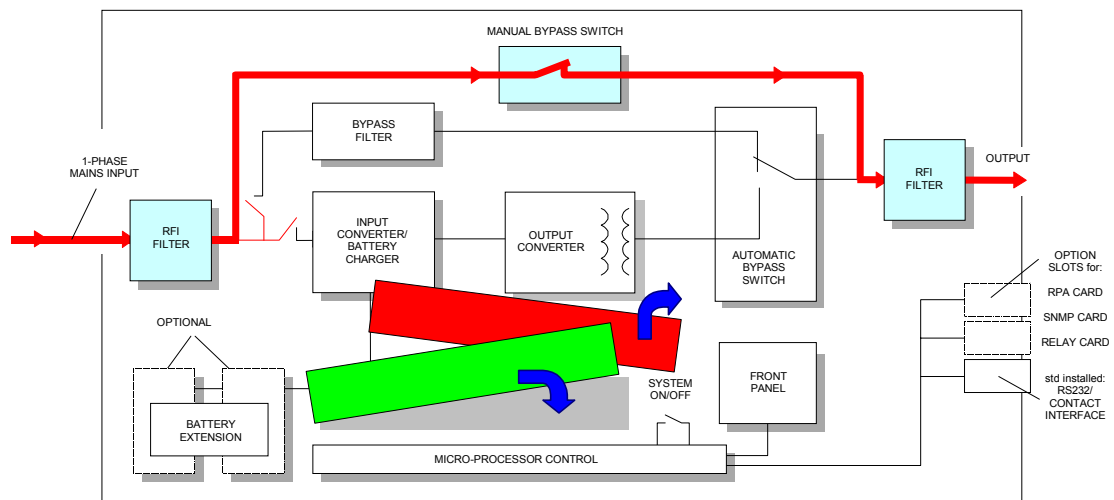

Figure 5. Bypass operation: manual bypass



## 4 - Installation

### 4.1 Unpacking

Cut the two wrapping bands, and remove the shipping box. Loosen the four bolts with which the UPS is fixed to the pallet. Remove the UPS from the pallet. **BE CAREFUL! HEAVY WEIGHT!** Never try to lift the unit by yourself! The UPS is equipped with castors, that allow easy displacement of the unit. Please take appropriate measures to avoid damage on vulnerable floors.

### 4.2 Package Contents

The shipping box contains a **LanPro** UPS, a CD-ROM, an RS232 cable, cable clamps, a customer reply card, a safety guide and this manual. If the UPS is equipped with an RPA plug-in card (Redundant Parallel Architecture, right option slot at the rear of the unit) the shipping box also contains a yellow network cable and one bus terminator. Inspect the UPS for damage after unpacking. If any damage is present please notify the carrier and place of purchase immediately.

### 4.3 Location

Please refer to section 1.3 of 'IMPORTANT SAFETY INSTRUCTIONS'.

### 4.4 Installation

#### IMPORTANT:

Before making any connection and switching on the **LanPro** UPS, please check the following conditions:

- the voltage and frequency of your utility supply is 220/230/240 Vac and 50/(60) Hz; off-factory the output of the UPS is set to 230 Vac / 50 Hz,
- the branch circuit supply is protected as follows:

UPS model	branch protection
LanPro 3kVA	16A slow
LanPro 5/6kVA	25A slow
LanPro 8kVA	50A slow
LanPro 10kVA	50A slow

Table 1. external input fuse value



**CAUTION:** To reduce risk of fire, connect the UPS only to a circuit provided with the fuse values according to Table 1 above.

- Ensure that the total power requirement of the equipment to be protected does not exceed the rated output power of the UPS. (output power for your unit is indicated on the rating label on the rear panel),
- The UPS must be grounded when in use: Connect the UPS to a single phase, three wire AC source equipped with an earth connection.

The following sections describe the installation of the **LanPro-11** UPS.

#### LanPro 3/5/6-11 UPS:

- 4.4.1 Standard installation **LanPro** 3/5/6-11.
- 4.4.2 Installation of **GE Digital Energy LanPro** battery extension pack(s).

#### LanPro 8/10-11 UPS:

- 4.4.3 Standard installation **LanPro** 8/10-11.
- 4.4.4 Installation of **GE Digital Energy LanPro** battery extension pack(s).

#### LanPro-11 UPS, general:

- 4.4.5 2 / 3 / 4 parallel operating units: additional information.





### 4.4.1 LanPro 3/5/6-11: standard installation procedure

If a battery extension pack is to be installed, please proceed with section 4.4.2.

If 2, 3 or 4 parallel operating units will be installed, please proceed with section 4.4.5.

The numbers between (brackets) refer to figure 12 in section 5.1.

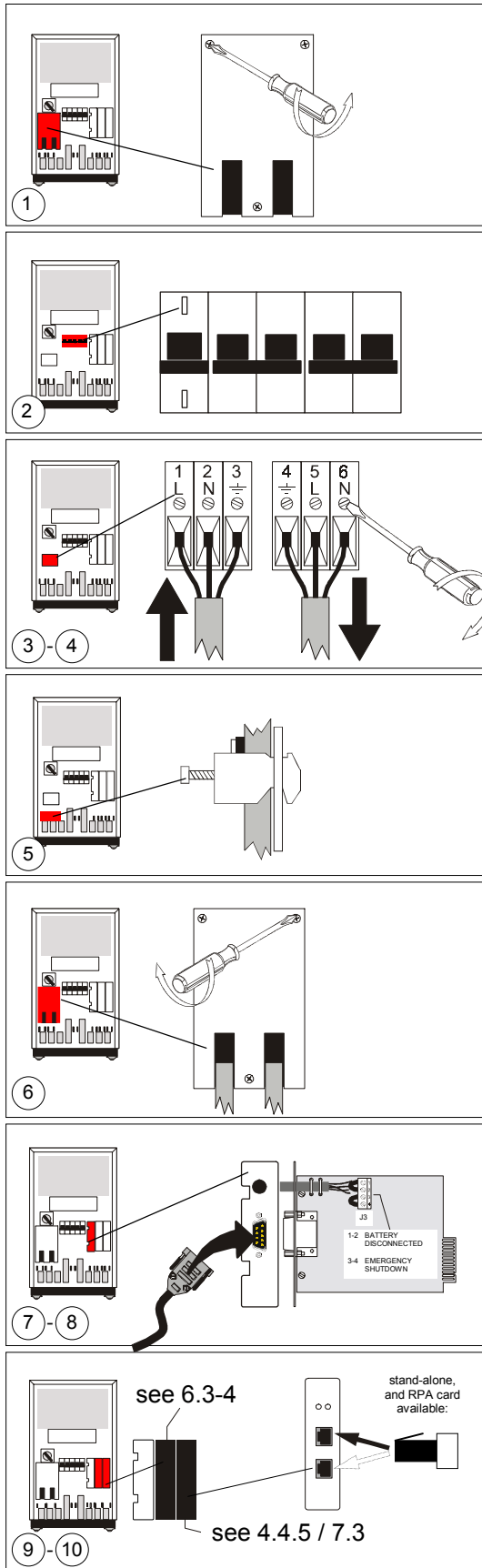

1. Loosen the 3 screws and remove the metal plate (11) that covers the I/O terminals.
2. Make sure that all circuit breakers (7-8-9) are in 'off' position (down).
3. Input (11a). Connect the mains supply wires to the terminals 1 (Line) and 2 (Neutral) and the ground wire to terminal 3. Ground connection is essential!
4. Output (11b). Connect the load wires to the terminals 5 (Line) and 6 (Neutral) and the ground wire to terminal 4. Ground connection is essential!
5. Use the clamps that came with the unit to attach the wires to the rear of the cabinet. Position the clamps in the slots (16).
6. Re-install the metal cover plate (11).
7. An emergency shutdown switch can be connected to connector J3 on the RS232/Contact Interface Card, between pins 3 and 4. See section 6.2 for more information.
8. For advanced communication possibilities, the RS232/contact interface port (12a) can be connected to a computer system. See section 6.1 for more information.
9. The middle 'option slot' (13) allows easy installation of plug-in cards: SNMP Card or Relay Card. See sections 6.3 and 6.4 for more information.
10. The right 'option slot' (14) allows easy installation of the RPA-card (Redundant Parallel Architecture). If the card is already mounted, and if the unit is intended to be used stand-alone, a bus terminator (delivered with the unit) has to be placed in one of the two bus connectors on the card. If the unit will be part of a parallel system, see sections 4.4.5 and 7.3 for more information.
11. Connect the utility power to the UPS.
12. For a quick start proceed with section 5.2 'Start-up'.

Figure 6. LanPro 3/5/6-11: Standard installation procedure



#### 4.4.2 LanPro 3/5/6-11: installation of GE Digital Energy LanPro battery extension pack(s)

The numbers between (brackets) refer to figures 12-13 in section 5.1.

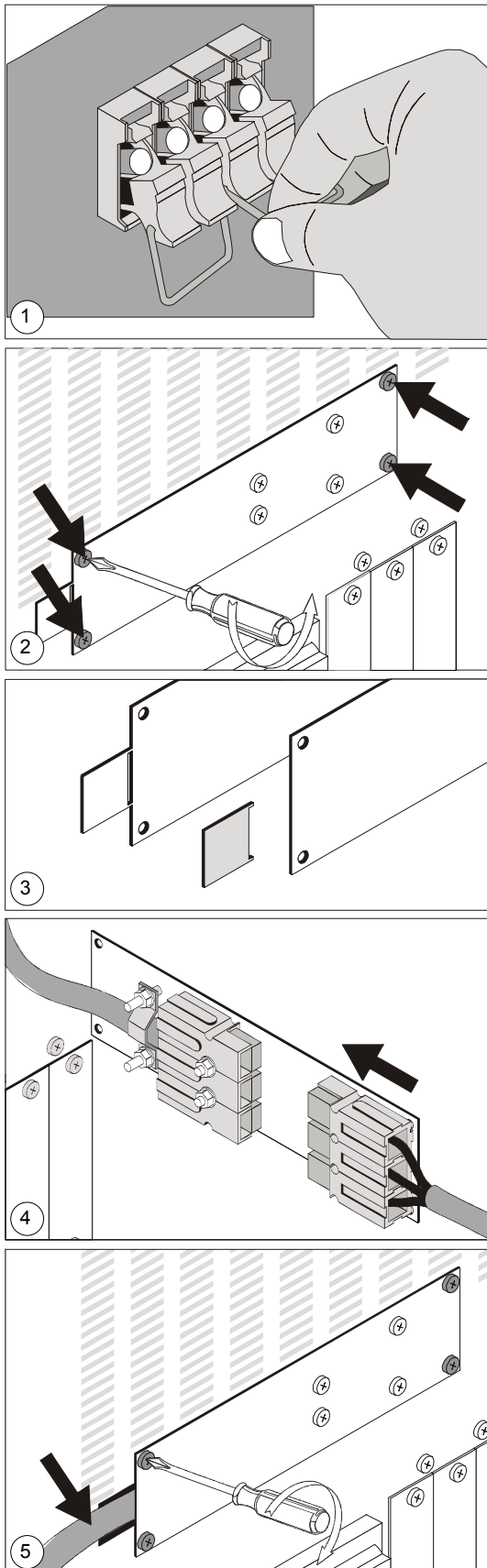

Figure 7. LanPro 3/5/6-11:  
Installation of battery pack

Battery extension pack(s) are shipped with all materials necessary to connect them to the UPS. The pack(s) can be connected to the DC connector (15) at the rear panel of the UPS. We recommend to switch off the UPS before proceeding: be sure that the UPS can be switched off without causing damage to the load, and turn all circuit breakers (7-8-9) into 'off' position (down).

1. Open the fuse holders at the rear panel of the battery pack (18) and make sure that the fuses have been removed.
2. UPS rear panel: loosen the 4 screws that hold the cover of the DC connector (15), and open the cover. The actual DC socket is fixed to the inner side of the cover.



**CAUTION!** The battery voltage is 240Vdc and is NOT isolated from the mains.

3. Break off the small part of the cover.
4. Connect the DC connector of the battery pack (15a) to the DC socket of the UPS (15). You will hear a click when the cable is properly installed.
5. Lead the DC cable through the hole on the left side of the cover of the DC connector (15) and re-install the cover. Fasten it with 4 screws.
6. Use the clamps that came with the unit to attach the DC cable to the rear of the cabinet. Position the clamp in the slots (16).
7. In case of 14Ah battery packs: using the DC connector of the battery pack (15) you can install a second, third, etc. pack. 7Ah battery packs cannot be connected in series.
8. Insert the 2 (7Ah) or 4 (14Ah) fuses of the (each) battery pack and close the fuse holder(s) (18).
9. In order to calculate the available back-up time related to the actual load, information on the capacity of the battery set is stored in the UPS. As the total battery capacity changes when battery extension packs are installed, the battery capacity must be re-programmed. See 5.3.4.

In case of a custom-built battery extension set you may want to install a 'battery disconnected' alarm device.

10. Be sure that the UPS is switched off, and disassemble the RS232/Contact Interface Card (12) from the unit. *If the card is disassembled during normal operation the UPS will shut down!* Remove the wire from connector J3 (pin 1 and 2). Install the wiring of a normally closed contact (e.g. an auxiliary contact of an MCB) to pin 1 and 2. Re-install the interface card. If the contact is opened, the UPS will generate an 'EXTERNAL BATTERY FUSE FAILURE'. See 5.3.2 for more information.

Proceed with 4.4.1 or 5.2.



### 4.4.3 LanPro 8/10-11: standard installation procedure

If a battery extension pack is to be installed, please proceed with section 4.4.4.

If 2, 3 or 4 parallel operating units will be installed, please proceed with section 4.4.5.

The numbers between (brackets) refer to figure 12 in section 5.1.

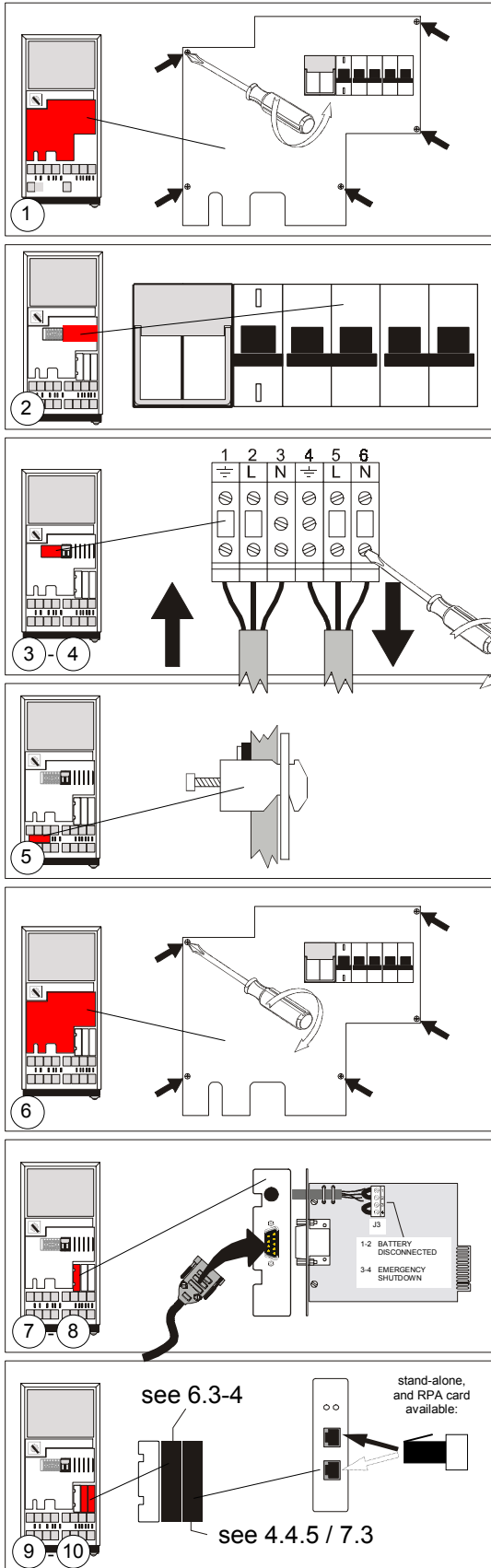

1. Loosen the 5 screws and remove the metal plate (11) that covers the I/O terminals.
2. Make sure that all circuit breakers (7-8-9) are in 'off' position (down).
3. Input (11a). Connect the mains supply wires to the terminals 2 (Line) and 3 (Neutral) and the ground wire to terminal 1. Ground connection is essential!
4. Output (11b). Connect the load wires to the terminals 5 (Line) and 6 (Neutral) and the ground wire to terminal 4. Ground connection is essential!
5. Use the clamps that came with the unit to attach the wires to the rear of the cabinet. Position the clamps in the slots (16).
6. Re-install the metal cover plate (11).
7. An emergency shutdown switch can be connected to connector J3 on the RS232/Contact Interface Card, between pins 3 and 4. See section 6.2 for more information.
8. For advanced communication possibilities, the RS232/contact interface port (12a) can be connected to a computer system. See section 6.1 for more information.
9. The middle 'option slot' (13) allows easy installation of plug-in cards: SNMP Card or Relay Card. See sections 6.3 and 6.4 for more information.
10. The right 'option slot' (14) allows easy installation of the RPA-card (Redundant Parallel Architecture). If the card is already mounted, and if the unit is intended to be used stand-alone, a bus terminator (delivered with the unit) has to be placed in one of the two bus connectors on the card. If the unit will be part of a parallel system, see sections 4.4.5 and 7.3 for more information.
11. Connect the utility power to the UPS.
12. For a quick start proceed with section 5.2 'Start-up'.

Figure 8. LanPro 8/10-11: Standard installation procedure



#### 4.4.4 LanPro 8/10-11: installation of GE Digital Energy LanPro battery extension pack(s)

The numbers between (brackets) refer to figures 12-13 in section 5.1.

Battery extension pack(s) are shipped with all materials necessary to connect them to the UPS. The pack(s) can be connected to the DC connector (15) at the rear panel of the UPS. We recommend to switch off the UPS before proceeding: be sure that the UPS can be switched off without causing damage to the load, and turn all circuit breakers (7-8-9) into 'off' position (down).

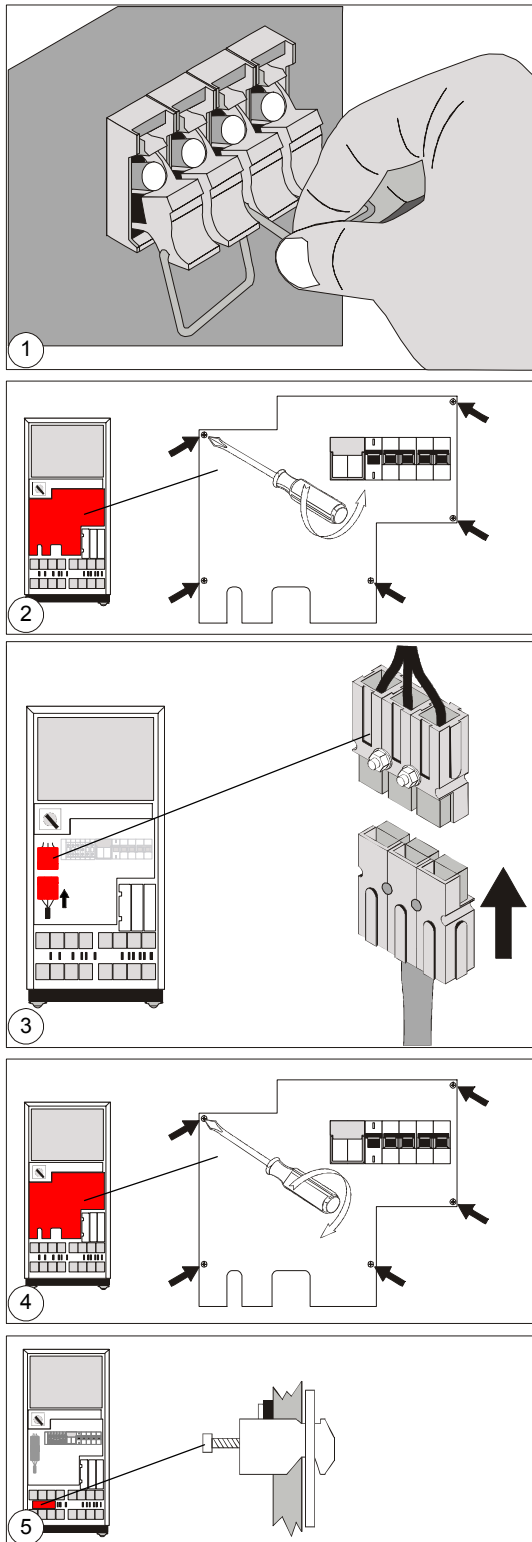



Figure 9. LanPro 8/10-11: Installation of battery pack

1. Open the fuse holders at the rear panel of the battery pack (18) and make sure that the fuses have been removed.
2. UPS rear panel: loosen the 5 screws that hold the cover of the DC connector (15), and open the cover.  
 **CAUTION!** The battery voltage is 240Vdc and is NOT isolated from the mains.
3. Connect the DC connector of the battery pack (15a) to the DC socket of the UPS (15). You will hear a click when the cable is properly installed.
4. Lead the DC cable through the slot in the cover (bottom-left) and re-install the cover. Fasten it with 5 screws.
5. Use the clamps that came with the unit to attach the DC cable to the rear of the cabinet. Position the clamp in the slots (16).
6. In case of 14Ah battery packs: using the DC connector of the battery pack (15) you can install a second, third, etc. pack. 7Ah battery packs cannot be connected in series.
7. Insert the 2 (7Ah) or 4 (14Ah) fuses of the (each) battery pack and close the fuse holder(s) (18).
8. In order to calculate the available back-up time related to the actual load, information on the capacity of the battery set is stored in the UPS. As the total battery capacity changes when battery extension packs are installed, the battery capacity must be re-programmed. See 5.3.4.

In case of a custom-built battery extension set you may want to install a 'battery disconnected' alarm device.

9. Be sure that the UPS is switched off, and disassemble the RS232/Contact Interface Card (12) from the unit. *If the card is disassembled during normal operation the UPS will shut down!* Remove the wire from connector J3 (pin 1 and 2). Install the wiring of a normally closed contact (e.g. an auxiliary contact of an MCB) to pin 1 and 2. Re-install the interface card. If the contact is opened, the UPS will generate an 'EXTERNAL BATTERY FUSE FAILURE'. See 5.3.2 for more information.

Proceed with 4.4.3 or 5.2.

**4.4.5 LanPro-11 series: 2 / 3 / 4 parallel operating units – additional info**

The RPA option (Redundant Parallel Architecture) allows you to create a redundant UPS system in which 2, 3 or 4 **LanPro** units operate in parallel. The following should be considered when installing units in parallel.

This section gives additional information on:

- installation (4.4.5.1)
- start-up (4.4.5.2)
- use / maintenance (4.4.5.3)

**4.4.5.1 Notes concerning installation of a parallel system**

1. All inputs of the UPSs must be supplied from the same phase. This is to enable bypass operation of the parallel system. All inputs must be individually protected by fuses in the installation. The values of these fuses should correspond to the values mentioned in section 4.4 table 1.
2. All outputs must be connected together, supplying the load. It is advised to install switches (S 1-4, fig. 10) in the output wiring, in order to be able to isolate a unit from the remaining system for service and maintenance purposes. It is advised to make a Neutral-to-Ground bounding in the output junction.
3. The diameter of input and output cables must be according to the table in the installation drawings (see appendix). Cables with different diameters can cause tripping fuses in the UPS and/or the installation.
4. The length of all input cables from the input junction (Li, fig. 10) to the UPS inputs should be equal. The same applies to the cables from the outputs to the output junction (Lo, fig. 10). The minimum length of the input as well as the output cables is 3 meters.

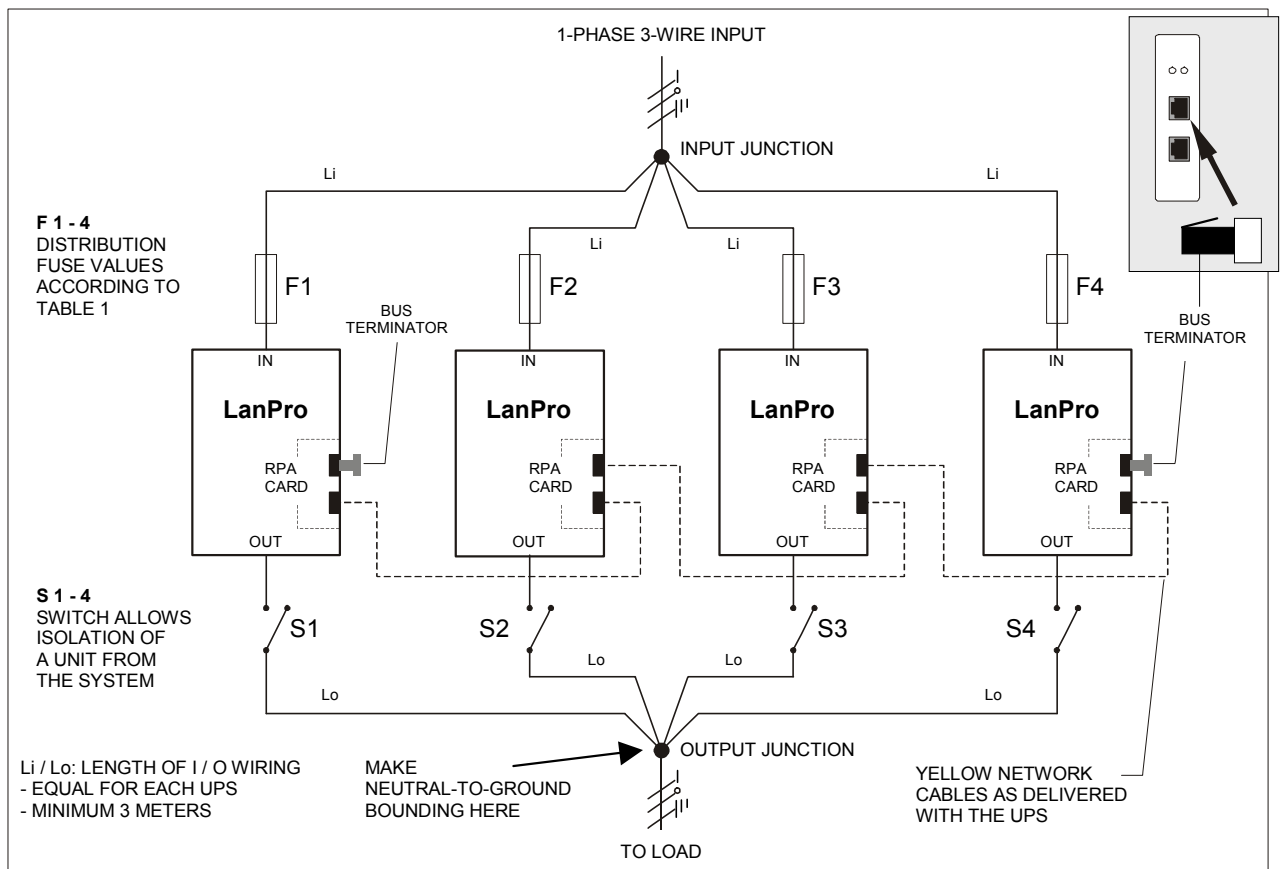

Figure 10. Installation of parallel operating LanPro-11 UPSs



5. The right option slot (14) at the rear of the unit contains the the RPA-card. Before the parallel system can be put into operation a unique number has to be appointed to each UPS in the system. This can be 0, 1, 2 or 3. Start with 0 for the first unit, 1 for the second, 2 for the third and 3 for the last unit:
  - loosen the screws, remove the RPA-card
  - set the dipswitch to the appointed number (fig. 11)
  - re-install the RPA-card, fasten the screws.

**Do NOT install the network cables between the RPA-cards of the units yet!**

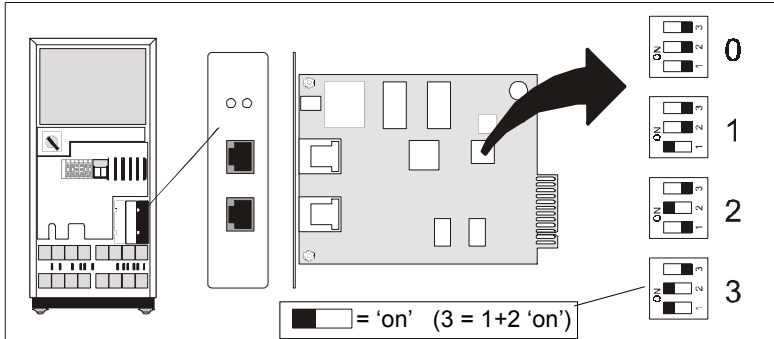

Figure 11. Appointing a unique number to each UPS in the system

6. In the UPS many parameters can be set. It is advised to keep the same setting for each parameter in each UPS in the parallel system. In any case the following parameters are critical and should have equal settings:
  - autorestart (on/off, see 5.3.3)
  - output voltage (220/230/240 Vac, see 5.3.4)
  - output frequency (50/60 Hz, see 5.3.4)

It is absolutely required that these parameters are set to the same value. Off factory this is the case. If you're not sure that the units have equal settings:

- be sure that the RPA-cards of the units have not been interconnected yet
- be sure that utility power is connected to the UPS
- start each unit individually (see 5.2), check / change the parameters, and switch the unit off again.

7. Interconnect the RPA-cards of the units, using the network cable that came with the UPS. See figure 10 (dotted line). Only use the cables that were delivered with the UPSs! Of the first and the last UPS in the system only one RPA-socket is used to interconnect the UPSs. A bus terminator must be placed in the other (free) RPA-socket. The required bus terminators have been delivered with the unit.

#### 4.4.5.2 Notes concerning starting up the parallel system

For starting up the system please refer to section 5.2.

After switching on all units the **LanPro** UPSs will show the following display:

```

AUTORESTART OFF
PRESS ENTER
  
```

After pressing on the enter button on one of the units the system will start up. All units will display the standard screen. The number in the lower right corner indicates the number of the UPS in the system.

```

LanPro 5-11
LOAD 40%      2
  
```

If the parameters mentioned in 4.4.5.1 step 6 are not set to the same value the UPS will display the following screen after start-up:

```

AUTORESTART OFF
SETTING MISMATCH
  
```

In this case check and correct the setting of the parameters as mentioned in 4.4.5.1, step 6.



#### 4.4.5.3 Notes concerning use / maintenance of a parallel system

**ECO-mode:**

If **LanPro** units operate in parallel, the ECO-mode feature is not available. See also 5.5.5.

**No-load shutdown:**

If **LanPro** units operate in parallel, the no-load shutdown function is not available.

**Manual bypass:**



If you want to switch one of the UPSs to bypass operation using the manual bypass switch (switch is turned into position 2) then all UPSs in the parallel system have to be switched to bypass operation in order to prevent damage.

**Maintenance:**

To isolate a unit from the redundant system:

1. Switch off the UPS which has to be isolated,
2. Remove the installation fuse from the input of that UPS (F1-4 in figure 10),
3. Separate the output of the UPS from the output junction (S1-4 in figure 10).

To re-enter the unit into the system:

1. Reinstall the installation input fuse,
2. Connect the output of the UPS to the output junction,
3. Switch on the UPS.



## 5 - Operation

### 5.1 Description of Front and Rear Panel

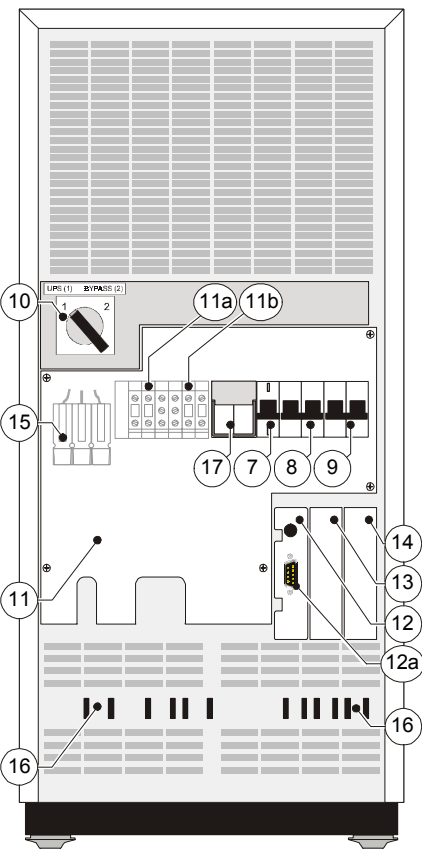
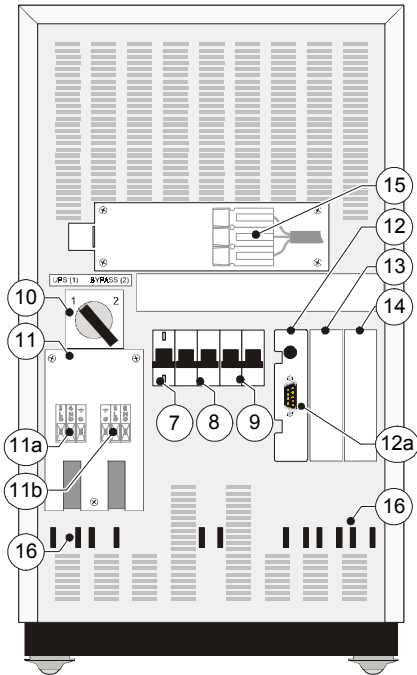
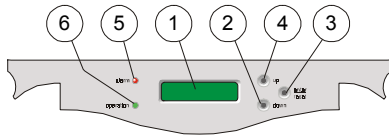

- 1 LCD screen  
2x16 characters, shows UPS system data, status messages, settings.  
The language is selectable: English, German, French, Italian, Spanish. Section 5.3.4 describes the selection procedure.
  - 2-4 Push-buttons  
With the button keypads 'down' (2) and 'up' (4) you can scroll through the several screens, with keypad 'reset/enter' (3) a selection is confirmed. Keypad activity is accompanied by a short beep. If there is no keypad activity during 20 seconds the LCD screen will return to the default screen (except for the service screens, see section 5.3.3).
  - 5 LED 'operation' indicates normal operation.
  - 6 LED 'alarm', indicates an alarm situation, accompanied by alarm message(s) on the display and a sounding buzzer. See section 5.3.2 for more information.
  - 7 Switch 'UPS on/off', turns on/off the complete UPS, including the bypass!
  - 8 MCB 'Mains on/off', protection fuse for mains input and battery charger.
  - 9 MCB 'Bypass on/off', fuse to protect the system in case of severe overload or short circuit in the UPS load.
  - 10 Manual Bypass Switch:     1 = Load on UPS  
  2 = Load on mains
- WARNING:** In position 2, if the input line is energized, the output is also live regardless the position of the MCBs 'mains' and 'bypass'.
- 11 Cover of the I/O terminals, behind it:
    - 11A Input terminals  
3/5/6kVA: 1 = Line, 2 = Neutral, 3 = Ground  
8/10kVA : 1 = Ground, 2 = Line, 3 = Neutral
    - 11B Output terminals  
4 = Ground, 5 = Line, 6 = Neutral
  - 12 RS232/Contact Interface Card, with:
    - 12a - RS232 Interface Port (see section 6.1)
    - Emergency shutdown (see 4.4.1 and 6.2)
    - Battery disconnected, pin 1-2 (can be used for external signaling).
  - 13 Free option slot for plug-in cards:
    - Relay Card (see 6.3)
    - SNMP Card (see 6.4)
  - 14 Option slot for RPA Card (Redundant Parallel Architecture). See 4.4.5 and 7.3.
  - 15 DC socket / connector.
  - 16 Slots to fasten cable clamps.
  - 17 Battery fuse holder.

Figure 12. Front and rear panel  
top: LanPro 3/5/6-11  
bottom: LanPro 8/10-11



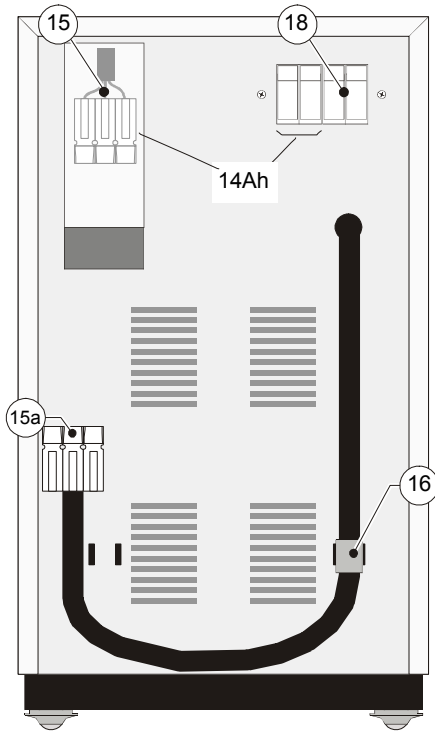

**Rear panel of (optional) battery extension pack:**

- 15 DC socket (14Ah only).
- 15a DC connector
  
- 16 Slots to fasten cable clamps.
  
- 18 Battery fuse holder(s)  
7Ah: 2 fuses  
14Ah: 4 fuses

*Figure 13. Rear panel battery extension pack (optional)*



## 5.2 Start-up

The numbers between (brackets) refer to figure 12 in section 5.1.

Note: the UPS can be started on battery power if the mains input voltage is not available or if MCB 'mains' is in off-position: simply skip step 1. To prevent accidental discharging of the batteries, it is however recommended to proceed with step 1 and start the unit only when the mains input voltage is available.

1. Turn MCB 'mains' (8) and MCB 'static bypass' (9), both on the rear panel, into position 'on' (up).
2. Some UPS parameters (e.g. voltage, frequency, LCD language) are user selectable. If you want to change one or more settings, please refer to section 5.3.4 'Setup Menu' now. Changing the settings later is possible, however only after switching off the unit.
3. Turn switch 'UPS on/off' (rear panel, 7) into position 'on' (up).  
The green LED 'operation' (front panel, 5) will illuminate.

After switching on the UPS performs a self-test and the display (front panel, 1) will show:



SELFTEST  
IN PROGRESS

After completion of the self-test the output voltage of the UPS is available and the unit is ready for use. The display will show the default screen: model and actual load (values are examples)

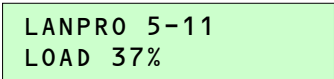

LANPRO 5-11  
LOAD 37%

In case of a system failure the self-test results in a failure message; this message is displayed for 30 seconds before the self-test is repeated automatically. If the faulty situation persists, switch off the UPS and contact your dealer. See chapter 9 for more information.

4. Though the batteries (the internal energy reserve) were fully charged when the UPS left the factory, they might have lost some energy during transport and/or storage. It is recommended to allow the UPS to recharge the batteries for a few hours. This way you ensure that the UPS can provide sufficient runtime in case of a mains power failure.
5. If not yet switched on, the equipment connected to the **LanPro** UPS can be switched on now; operate as usual.



### 5.3 Use

Once the unit is in operation, there is no need to switch the unit on/off during use.

If the manual bypass switch (rear panel, 10) is in position '1', switching off by the on/off switch (rear panel, 7) results in a total absence of the output voltage (also the bypass voltage) of at least 5 secs.

If an emergency shutdown switch has been installed (see 4.4.1, step 7) the UPS will stop immediately when the switch is opened. Restart is only possible after closing the switch and turning the UPS **off** and **on** again with the UPS on/off switch (rear panel, 7).

The UPS is operated via the push-buttons (front panel, 2-3-4) and the LCD display (front panel, 1). Furthermore the UPS can be controlled via the RS232/contact interface port (rear panel, 12a). For more information see 6.1.

The menus on the display can be divided into 5 groups:

- 1 standard screen
- 2 information menu (5.3.1)
- 3 status- and alarm menu (5.3.2)
- 4 service menu (5.3.3)
- 5 set-up menu (5.3.4)

The *standard menu* shows UPS model and actual load.

```

LANPRO 5-11
LOAD 37%

```

#### 5.3.1 Information menu

When the default screen is displayed the first information screen can be entered by pressing the 'up' key (front panel, 4). Using the 'up' and 'down' keys (front panel, 4 and 2) you can scroll through several information screens. After the last information screen the default screen will appear.

The screens display the following information:

<pre> INPUT LINE  226V 2.45kW      50Hz </pre>	Mains voltage and utility frequency, and the power delivered by the mains.
<pre> OUTPUT      230V LOAD 50%    50.0Hz </pre>	Output voltages and output frequency, and the power delivered by the UPS (as % of the nominal UPS rating).
<pre> BATTERY     23°C 271V        1.9A </pre>	The temperature near the batteries, the battery voltage and the battery current (charging: + value, discharging: - value).
<pre> AUTONOMY TIME LEFT 10:30 </pre>	The remaining battery runtime (or autonomy) during a mains failure.
<pre> OPERATING TIME OYEAR 29DAYS </pre>	The total operating time of the UPS.



### 5.3.2 Status and alarm menu

The UPS alerts the user with a standard alarm screen that the operating mode has changed and/or that an alarm situation occurs:

ON LINE  
ALARM (PRESS UP)

The actual operating mode, the possible modes are mentioned below. The lower line -if displayed- shows that an alarm occurred. More information can be retrieved with the 'up' key. If no further information is available, the second line is blank.

Possible operating modes:

- ON LINE                      The normal operating mode. For more information see section 3.2.
- ON BYPASS                Overload or failure situation. For more information see section 3.5.
- ON BATTERY              For a detailed description of this mode see section 3.3.
- OUTPUT OFF              No power is delivered to the load. This can be the result of a command via the RS232 Port, or because no electric energy is available (utility failure, depleted batteries).
- ON MANUAL BYPASS      Service mode. For more information see section 3.6.

Pressing the 'up' key from the standard alarm screen shows, in priority order, which alarms are active,. Scroll through the screens with the 'up' and 'down' keys. Alarm message texts can succeed each other. The following messages are possible:

LOADnotPROTECTED  
CAP. C2 DEFECT

The output capacitor C2 is defective. Contact your dealer.

UPS OVERLOADED  
REDUCE LOAD

The load exceeds the rated output power of the UPS, and the output voltage can no longer be guaranteed. This text alternates with the following screen:

LOADnotPROTECTED  
LOAD 107%

showing the actual load as % of the nominal UPS rating. These messages are displayed if the load is > 100%. If the load exceeds 150% the UPS will immediately switch to bypass, assuming that the conditions for a transfer to bypass are fulfilled. If an overload condition between 100-150% persists, the UPS can eventually also switch to bypass operation due to temperature protection. If a transfer to bypass is inhibited (due to voltage or frequency errors of the mains supply) the UPS may automatically switch off within a few seconds (load dependent). *Output power is lost at that moment.* To avoid these problems, be absolutely certain that the power demands of the protected equipment are within the limits of the UPS.

LOADnotPROTECTED  
TEMP TOO HIGH

The temperature of the heatsinks or output transformer is too high. As a result the output voltage may be transferred to bypass.

The operating temperature can rise to intolerable levels as a result of:

- extreme environmental temperature
- lack of proper ventilation
- an overload situation
- fan failure

If the UPS operates in 'on line' mode, it will switch to bypass until the temperature is normal again. If however the UPS operates 'on battery', a shutdown will occur and output power is lost.

LOADnotPROTECTED  
VOLTAGE TOO HIGH

The internal DC voltage is too high, internal failure

BATTERY CHARGER  
VOLTAGE TOO HIGH

The output voltage of the battery charger is too high, internal failure

BATTERY CHARGER  
TEMP TOO HIGH

The battery temperature is too high due to a battery failure or a too high ambient temperature

BATTERY CHARGER  
NO FLOAT

After 24 hours of charging time, the battery voltage did not reach the normal float voltage. This may be caused by faulty batteries, too many battery packs connected or a charger fault.



CAPACITOR C1 CAPACITY LOW	The main DC-capacitor needs replacement due to aging or failure
LOADnotPROTECTED INVERTER OFF	Due to a failure the output converter's output is not available. As a result the load may have been transferred to bypass.
LOADnotPROTECTED BATTERY DEPLETED	The remaining runtime is zero. As a result the load may have been transferred to bypass.
LOADnotPROTECTED BATTERY LOW	The remaining runtime is less than the set time (standard 2 minutes). This text alternates with the following screen:
UPS SHUTDOWN LEFT 2 MINUTES	The output voltage can be lost after the indicated time due to discharged battery. Controlled shutdown of any computer equipment is absolutely necessary at this point. (Using the RS232 or SNMP communications interface, this procedure can be initiated automatically on unattended systems). If the UPS operates at 100% load, the shutdown procedure should be completed within 2 minutes after the 'battery low' alarm started. When the batteries are fully discharged, the UPS is no longer able to power the connected equipment.
BYPASS ERROR FUSE FAILURE	The static bypass MCB (rear panel, 9) is in 'off' (down position): no bypass voltage available. Mains voltage is available. If not manually operated, this may have been caused by an overload situation.
INPUT ERROR FUSE FAILURE	The mains MCB (rear panel, 8) is in the 'off' (down position): no line voltage available, bypass voltage is available. If not manually operated, this may have been caused by an internal system failure.
INTERNAL BATTERY FUSE FAILURE	The internal battery fuse is defective; this may have been caused by an internal system failure. This alarm also appears if no batteries are installed.
EXTERNAL BATTERY FUSE FAILURE	The (custom-built) battery extension set has been disconnected from the system: its energy reserve is not available. See 4.4.2 step 12 for details.
REPLACE BATTERY	The batteries are (almost) chemically worn out. If the batteries are aged, they must be replaced as soon as possible to ensure full protection for your equipment (see section 8.3).
INPUT out LIMITS 137V 50.0Hz	The mains voltage or mains frequency are outside UPS input tolerance (see chapter 10, specifications)
BYPASSoutLIMITS 197V 50.0Hz	The mains voltage or mains frequency are outside bypass input tolerance but inside UPS (rectifier) input tolerance (see chapter 10, specifications). Bypass operation is inhibited: if for whatever reason the output converter is unable to deliver the required output, output power is lost.
INPUT AND OUTPUT NOT SYNCHRONIZED	The output converter frequency is not synchronized to the mains (input) frequency. In this situation the automatic bypass switch is not able to transfer the load from output converter to bypass and reverse: automatic bypass operation is inhibited: if for whatever reason the output converter is unable to deliver the required output, output power is lost. (see section 3.5). Synchronization is only possible if the mains frequency remains within certain limits (see chapter 10).
AUTONOMY TIME LEFT 0:09:41	The remaining runtime. This figure is counted down during battery operation until either the mains returns or the batteries are depleted.



OUTPUT OFF  
NO INPUT POWER

The output is switched off due to a faulty situation, indicated by the second line.

PROG. SHUTDOWN  
WITHIN 0:09:17

The output will be switched off via the RS232 interface. The second line indicates the time until shutdown.

PROG. SHUTDOWN  
LEFT 0:14:03

The output is switched off by a remote command (RS232/SNMP). The second line indicates the time until wake-up.

SHUTDOWN  
ALARM (PRESS UP)

The output is switched off by the 'no-load shutdown' feature: no input voltage and no load. If the input voltage is restored, the output will be available again.

IMMEDIATE  
SHUTDOWN

The wire on connector J3 pin 3-4 (rear panel, plug-in card 12) is interrupted. The output is no longer available. To restart the unit, restore the connection and turn the on/off switch (rear panel, 7) off and on again.

### 5.3.3 Service menu

When the default screen is displayed you can enter the first service screen by pressing the keys 'down' (2) and 'enter/reset' (3) simultaneously for approx. 1 second. Using the 'up' (4) and 'down' (2) keys you can scroll through several service screens.

SERVICE SCREENS  
ENTER            exit

The intro service screen. 'Enter/reset' returns to the default screen.

SERIAL NUMBER  
L051/01 0020A030

The serial number of the UPS.

SOFTWARE VERSION  
R1.0; 640777

Release number of the installed software and production code of the UPS.

FAN SPEED            10  
INV.DC: + 375

Service information about fan speed (min. 10, max. 30) and internal DC voltage.

HEATSI.TEMP:        0  
TRANSF.TEMP:       310

Service information on internal temperature levels, values in mV over the temperature sensors.

FLOAT CHARGE:       1  
OUTPUT FAST :       0

Upper line: '1' = batteries have reached float voltage.  
Second line: service information on output converter.

TSTAMP                Q4  
6028773                1

Service information on internal timer.

FREQ RANGE:         2%  
NO LOAD               :     1

Frequency tracking range: output converter frequency will follow the bypass frequency within these limits before returning to its own internal frequency. Standard setting: nominal  $\pm 2\%$ . Can be changed into nominal  $\pm 4\%$  or  $\pm 6\%$ . See 5.3.4 Setup Menu.

No-load shutdown: after a 10 minutes delay the UPS will shut down during utility failure if the load is  $< 2\%$ . It will restart after the mains returns or when the unit is switched off and on again.

Default setting = 1 (active). For disabling this feature see 5.3.4.

QUICK BATTERY  
TEST PRESS ENTER

Start of the manual Quick Battery Test.  
See for more information section 5.4.2 'Quick Battery Test'



CALIBRATE BAT PRESS DOWN+ENTER	Start of the manual Deep Battery Calibration Test. See for more information sections 5.4.3 'Deep Battery Calibration Test'
PF1 THYRISTOR 1 BATT. THYRISTOR 0	Service information on internal UPS components
VSS THYRISTOR 0 PF1. CONVERTER 1	Service information on internal UPS components
BAT CHARGER 2 INVERTER 1	Service information on internal UPS components Batt.Charger: 0 = off, 1 = float charging; 2 = boost charging
LAST TEST TIME 0:00:00	Duration of latest test performed, hh/mm/ss
FORCE BYPASS press DOWN+ENTER	The UPS transfers the load to bypass when the keys 'down' (2) and 'enter/reset' (3) on the front panel are pressed simultaneously for approx. 2 seconds. If the bypass supply is not within limits, the lower line will show the text 'UNAVAILABLE'.
AUTOMATIC BYPASS ENABLED	Service set up information whether the bypass is enabled (default) or disabled. If disabled: UPS will NOT go to bypass. For disabling the bypass refer to the setup menu (5.3.4).
BATTERY 7Ah BAT. CHARGE 86%	Service set up information about the total battery capacity. Information about the actual battery charge condition. For changing the programmed battery capacity refer to the setup menu (5.3.4).
PLL LOCK SPEED NORMAL	Service set up information about frequency tracking speed for the inverter to follow the bypass frequency, LOW (1Hz/sec.) is the normal value and default. HIGH (5Hz/sec.) may be suitable if the UPS is connected to a generator with fast frequency changes and the UPS must be synchronized to prevent alarms. For changing the lock speed refer to the setup menu (5.3.4).
IEMMODE DISABLED ENTER/RESET CHNG	Service set-up information about the ECO-mode. By pressing 'ENTER/RESET' the ECO-mode can be enabled or disabled, depending on the actual status. In this way the load will be supplied by way of the electronic bypass. If the ECO-mode is disabled the load will be supplied by the inverter. See also 5.5.5.
AUTO RESTART ON ENTER/RESET CHNG	Service set-up information about the autorestart function. This function can be switched on or off by pressing 'ENTER/RESET', depending on the actual status. See also 4.5.6.





### 5.3.4 Setup menu

To enter the setup menu:

1. Be sure the UPS is switched off.
2. Press push-button 'enter/reset' (front panel) and *simultaneously* turn switch 'UPS on/off' (rear panel) into position 'on' (up).

Using push-buttons 'up' and 'down' you can scroll through the several setup screens, 'enter/reset' confirms a screen choice. After selecting a setup screen you can scroll through its settings using the push-buttons 'up' and 'down', a setting is confirmed by pressing 'enter/reset'. To abort the setup procedure (i.e. without changing the setting) just wait the 20 seconds time-out period after which the default screen will return.

SETUP SCREENS  
ENTER/RESET exit

The intro setup screen. 'Enter/reset' returns to the default screen. You can also wait 20 seconds: the time-out period of no key activity.

Pressing 'up' displays the screens in the following order:

WARNING: OUTPUT  
CHANGES ON LINE

A short reminder that the new settings will be valid immediately after pressing the 'enter/reset' key.

LANGUAGE  
ENGLISH

Changes the language of the screen messages: you can select English, German, French, Italian, Spanish.

OUTPUT VOLTAGE  
230V

The system output voltage. Range: 220/230/240 Vac

OUTPUT FREQUENCY  
50.0Hz

The system output frequency. Range: 50/60 Hz.



**CAUTION!** Changing of the output frequency can cause severe damage of equipment connected to the UPS: Be sure that the new frequency is suitable for the connected equipment.

FREQUENCY RANGE  
2%

The frequency tracking range (in which the output converter frequency will follow the bypass frequency). Range: 2/4/6 %. If the bypass frequency is beyond the setting, the output converter will return to the fixed crystal controlled frequency.

PLL LOCK SPEED  
NORMAL

The frequency tracking speed range (in which the output converter frequency will follow the bypass frequency). Range: NORMAL (1Hz/sec), HIGH (5Hz/sec).

BATTERY CAPACITY  
7Ah

Battery capacity. Range: 7 through 590 Ah, in 1 Ah steps.



**WARNING!** If you proceed, the information about the actual battery condition (as a result of a deep battery test) is lost. For more info see section 5.4.3 'Deep Battery Test'.

FAN CURVE  
0

The fan speed. Range: 0 / 1. Proper setting optimizes the cooling capacity of the fans installed. **DO NOT READJUST!** Incorrect setting may lead to reduced lifetime of the power semiconductors.

NO-LOAD SHUTDOWN  
YES

Setting 'YES' means that the function is activated: the UPS will switch off during a mains failure when the load is less than 2% of the maximum load. Range: YES/NO. NOTE: if the **LanPro** operates in parallel the no-load shutdown function is not available. In this case do not activate this function: its setting should read "NO".

AUTOMATIC BYPASS  
ENABLED

Controls functioning of the automatic bypass switch. Range: ENABLED/DISABLED. If the UPS is used as a frequency converter you may change the setting to 'DISABLED'. Bypass operation will then be inhibited and all alarms related to 'bypass out of limits' are suppressed.

SERVICE WARNING  
DISABLED

The system can prompt for service to a user defined schedule. Range: 8/12/16/20/24/28 months or DISABLED. The timer is reset when the UPS is switched off and on again.





## 5.4 Test Screens

These screens show the test procedure, either started from the service menu (front panel keys) or via the UPS monitoring software (RS232/SNMP). The upper line indicates the kind of test, the second line its status.

Upper lines:

second line:

<b>GENERAL SYSTEM</b>	<b>TEST START</b>	the test will start soon
<b>QUICK BATTERY</b>	<b>TEST ACTIVATED</b>	the test is running
<b>CALIBRATE BAT</b>	<b>TEST SUCCESSFUL</b>	the test has been completed successfully
<b>BYPASS</b>	<b>TEST FAILED</b>	the test has not been completed successfully

### 5.4.1 Battery test, general

**Automatic test:** Every 500 operating hours the UPS conducts automatic battery tests to ensure that the batteries and the wiring are able to support power failures. The tests do not cause any interruption in the functioning of the unit.

**Manual test:** A manual battery test can be activated

- either through an interface kit, via the RS232 or SNMP Interface Port (please refer to the manual of your interface package), or
- via the front panel: see below

### 5.4.2 Quick battery test

From the standard menu first enter the service menu (press the 'down' and 'enter/reset' keys simultaneously, then press the 'down' key until the following screen appears:

```

QUICK BATTERY
TEST PRESS ENTER

```

The enter/reset key confirms the selection, and the screen shows:

```

QUICK BATTERY
TEST START

```

The test status (indicated by the second line) can be:

<b>TEST ACTIVATED</b>	=	testing
<b>TEST SUCCESSFUL</b>	=	battery has been tested with positive result
<b>TEST FAILED</b>	=	the batteries should be replaced
<b>NOT AVAILABLE</b>	=	battery capacity too low to start the test

If the batteries are dangerously close to being worn out, a low priority alarm 'replace battery' will be generated. The batteries must be replaced as soon as possible (see section 8.3).

NOTE: If the manual test is started immediately after installation or after a power failure, the UPS may generate a false 'replace battery' alarm as the batteries have been (partly) discharged during transport/storage or during the power failure.



### 5.4.3 Deep battery test

The runtime as shown on the LCD screen is calculated, and the value is initially based on the capacity of new batteries. As batteries age, their capacity deteriorates, and as a result the initial battery capacity may be too unreliable for a proper runtime prediction. The UPS is able to keep track of the aging process, if a 'deep battery test' (battery calibration test) is executed regularly. During such a test the condition of the batteries is tested, and the result of the test is stored, and used by the UPS system for future runtime calculations.

We advise performing a deep battery test on a regular basis. For accuracy reasons the interval should depend on the number of discharges. With one discharge per month a 6 month interval is sufficient. If the discharge interval is shorter than once a week a monthly deep battery test is advised.

A deep battery test can be started only if the following conditions are met:

- The load should be more than 30% of nominal load
- The batteries should be fully charged (100% on screen)
- There are no alarms at the time the test is started.

**Procedure:**

From the standard menu first enter the service menu (press the 'down' and 'enter/reset' keys simultaneously for 2 seconds). Subsequently press the 'down' key until the following screen appears:

```
CALIBRATE BAT
press DOWN+ENTER
```

Press the keys 'down' (2) + 'enter/reset' (3) simultaneously, for at least 1 second.

The following screen appears:

```
CALIBRATE BAT
TEST ACTIVATED
```

The test is executed, this may take a few minutes with standard battery and full load. Partial load and/or batt. extension packs can lengthen the test period considerably. Do not change the load during the test, i.e. do not switch off or on connected equipment!

The deep battery test discharges the batteries to 'battery low' alarm level (see section 5.3.2 'battery low'). Please note that immediately after a deep battery test the expected runtime is very short: allow the UPS to recharge its batteries.

After the test the second line informs about the result:

- |                       |   |  |
|-----------------------|---|--|
| <b>TEST SUCCESFUL</b> | = | The test has been completed succesfully  |
| <b>TEST FAILED</b>    | = | The test could not be executed properly: not all test conditions were fulfilled.<br><i>The UPS system was not informed about the actual battery condition!</i> |



## 5.5 Other Features

### 5.5.1 Shutdown

'Remote shutdown': Using communication capabilities, the computer can direct the UPS to turn itself off following controlled shutdown of the system. Subsequently the UPS will remain off for at least a few seconds (see also 6.1). LED 'operation' will blink green. The unit will start up again as soon as the mains returns.

'No-load shutdown': The UPS will also switch off if the load is < 2% of the maximum load, and the input is absent for more than 10 minutes. For more information see section 5.3.2, message 'SHUTDOWN ALARM'.

**NOTE:** If the **LanPro** UPS operates in parallel, the no-load function is not available.

'Emergency shutdown': for more information see section 5.3.2, message 'IMMEDIATE SHUTDOWN'.

### 5.5.2 Mains start

The UPS is able to start, even if the batteries are not connected. Alarm messages 'BATTERY FUSE FAILURE' and 'BATTERY DEPLETED' will be shown. The runtime is zero.

### 5.5.3 Sleep and wake-up

**GE Digital Energy** UPS monitoring software allows you to program a 'sleep period' of the UPS by sending two commands to the UPS:

- shut down after # minutes, and subsequently:
- shut down during # hours.

After the first command the following screen appears:

```

PROG. SHUTDOWN
WITHIN 0:09:17

```

During the sleep period the output voltage is no longer available. LED 'operation' blinks green, and the LCD screen shows the time left until restart:

```

PROG. SHUTDOWN
LEFT 0:14:03

```

If a utility failure occurs during the sleep period and the battery voltage eventually drops below 200Vdc, the UPS will automatically switch off in order to save battery power. When the main returns the UPS will start up automatically. The programmed sleep time however is lost.

The sleep period can be cancelled by either turning the UPS ON/OFF switch (6) off for a few seconds or by sending the appropriate command via the RS232/SNMP port.

### 5.5.4 Overload protection in bypass mode

The **LanPro** will protect itself in case of overload. Upon an overload which is caused by abnormal circumstances the UPS will switch to bypass operation, and subsequently the bypass input fuse on the rear panel will trip. The capacity of the bypass fuse allows it to handle the inrush currents of the equipment connected to the UPS. The fuse will only trip after more than an hour at an input current of 40Amp (LP 3/5/6) or 50Amp (LP 8) or 63Amp (LP 10).

In order to protect the UPS system the software will cut off the abnormal current:

	in 10 minutes:	in 1 minute:
LP 3:	18Amp	27Amp
LP 5/6:	30Amp	45Amp
LP 8:	45Amp	65Amp
LP 10:	60Amp	73Amp

Between 18-27Amp (LP 3), 30-45Amp (LP 5/6), 45-65Amp (LP 8) or 60-73Amp (LP 10) the time is inversely proportional to the input current. We advise to place a distribution fuse slow blow type between UPS input and the mains supply. Please refer to the installation drawings.



### 5.5.5 ECO-mode

The **LanPro** UPS is equipped with the 'ECO-mode' feature. If the feature is enabled, the load is operated on mains through the electronic bypass switch. If the mains is interrupted or out of limits the load is automatically transferred to the inverter. Operating the load on mains improves the efficiency of the UPS with 5-8% and saves on energy costs. As the unit produces less heat in ECO-mode, also the energy costs of an airco installation will be reduced. We advise not to use the ECO-mode in case of an unstable mains supply.

NOTE: If **LanPro** units operate in parallel, the ECO-mode feature is not available. See also 4.4.5.3.

After enabling the ECO-mode (please refer to service screens 5.3.3) the *standard menu* changes to:

```
LANPRO 5-11
LOAD 37%   IEM
```

### 5.5.6 Auto restart

If this feature is enabled and the unit has shut down (e.g. due to overload) the UPS will start up automatically when the normal situation is restored. The off-factory setting is: enabled.

If the auto restart feature is disabled the unit will not automatically restart when the normal situation is restored but the display will show:

```
AUTO RESTART OFF
PRESS ENTER
```

After 'Enter' the unit will restart. See also 5.3.3 'service screens'.

### 5.5.7 Superior battery management

- **Load dependent battery-end voltage:** The allowable final battery voltage depends on the discharge current: the higher the current, the lower the 'end-of-discharge' battery voltage. This gives maximum capacity without over discharging. Over discharging results in failure to recover normal capacity and in shortened battery life.
- **Equalize mode:** When switched on for the first time the UPS will start boost-charging the batteries for 15 hours in order to equalize all battery voltages.
- **Boost mode:** If after a discharge the battery voltage is lower than 240Vdc (LP 3-11: 144Vdc), the UPS will charge the batteries with a boost charge voltage of 295Vdc (LP 3-11: 177Vdc). This enables fast recharging of the batteries. The programmed battery charging mode will change from boost charge into float charge after boost charging twice.
- **Temperature compensated battery charging:** This feature reduces the battery charge voltage with increasing temperature (-18mV/°C per 12V battery). As a result poor charging of the batteries under low temperature conditions and overcharging of the batteries under high temperature conditions are prevented.



## 6 - Interfacing Features

The UPS is equipped with 3 'option slots' (rear panel, 12-14). In the most left slot (12) an RS232/contact interface card is factory installed. See 5.1. In the middle slot (13) additional Relay or SNMP plug-in Cards can be installed. The most right slot (14) allows easy installation of an RPA plug-in Card (RPA - Redundant Parallel Architecture).

### 6.1 RS232 / contact interface

The RS232/Contact interface (9-pole, sub D, rear panel, 12a) enables advanced communication between the UPS and e.g. a personal computer. An interface kit (cable and software) is delivered with the UPS. The software supports most common operating systems incl. Novell, UNIX, VMS, Windows, IBM OS/2, LINUX, has a modular and layered architecture and works for all degrees of network complexity: stand-alone, multi-vendor networks and large managed networks.

During a power failure the UPS software takes a number of actions: processes are stopped, open files are closed and unattended systems will be shut down in a controlled way. When the mains power returns, the systems will automatically start up and will be up and running as soon as possible.

For specific information on **GE Digital Energy's** connectivity products please contact your dealer or internet: [www.gedigitalenergy.com](http://www.gedigitalenergy.com).

Pin #	Function
1	Battery low
2	Serial data out
3	Serial data in / UPS shutdown
4	Not used
5	Common
6	Bypass active
7	Plug&Play / RTS
8	Utility failure
9	General alarm

contact interface: Max 48V / 30mA

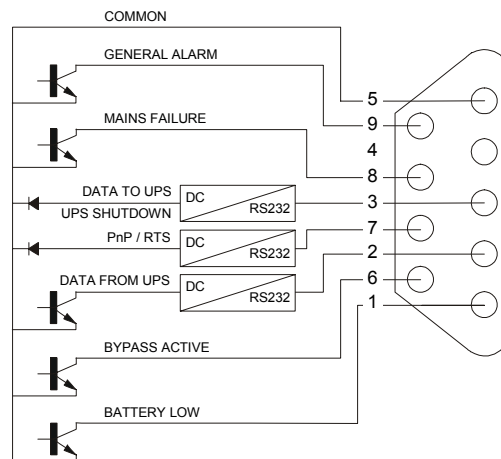

Fig. 14. RS232 / contact interface

### 6.2 Emergency shutdown

The emergency shutdown connector is located on the RS232/contact interface card (12). Be sure that the UPS is switched off, and disassemble the card from the unit\*. Remove the wire from connector J3 (pin 3 and 4). Install the wiring of a normally closed contact to connector J3 (pin 3 and 4). Re-install the RS232 interface card. If during normal operation of the UPS the contact is opened, the UPS will shut down. To restart the unit, restore the connection and turn the UPS off and on again.

\* If the card is disassembled during normal operation the UPS will shut down.

### 6.3 Relay Card (optional)

The relay plug-in card can be installed in the middle option slot (rear panel, 13). The card is provided with four potential free contacts representing: battery low, bypass active, mains failure and general alarm. For more information please refer to the user manual that comes with the interface card.

### 6.4 SNMP Interface (optional)

This SNMP plug-in card can be installed in the middle option slot (rear panel, 13). The card makes the UPS 'SNMP manageable': it allows the data interface to be connected directly to an Ethernet network (thin coax, twisted pair, AUI). For more information please refer to the user manual that comes with the interface card. When this option is installed the RS232 communication link is no longer available.



## 7 - Optional Features

### 7.1 Extended Runtime

Extended runtime versions are equipped with additional separate battery packs to increase the runtime of the unit. Additional batteries will increase the recharging time for the unit. All other operational information is the same.

If a battery pack is connected, the UPS must be informed about the new total battery capacity to allow a reliable recalculation of the available runtime. Please refer to section 5.3.4 'Setup Menu'. Dependent of the charge condition of the new batteries the new runtime calculations may temporarily be unreliable.

Battery pack A: 240V / 7 Ah  
Battery pack B: 240V / 14 Ah

Batt. pack(s)	cap. of batt. pack(s) (Ah)	tot. cap. incl. internal battery (Ah)		runtime (minutes), at 100% / 50% load			
		5/6-11	8/10-11	LP 5-11	LP 6-11	LP 8-11	LP 10-11
-	-	7	12	10/25	8/20	11/29	8/22
A	7	14	19	25/60	21/50	22/50	16/39
B	14	21	26	45/90	35/75	33/70	25/57
A+B	21	28	33	60/120	50/100	44/90	34/70
B+B	28	35	40	80/150	65/130	55/110	43/90

### 7.2 Plug-in Cards

An option slot (rear panel, 13) allows easy installation of a Relay plug-in card or SNMP plug-in card. See sections 6.3 and 6.4 for more information.

### 7.3 RPA-Facility (Redundant Parallel Architecture)

Nowadays there are many mission-critical applications that need a fault tolerant, 100 % reliable availability of mains power. By adding the RPA-facility to the **LanPro-11** (rear panel, 14), highest standards for reliability can be met. The RPA-facility allows to connect 2, 3 or 4 units in parallel.

Connecting **GE Digital Energy LanPro** units in parallel is attractive for several reasons.

**Redundancy:** To achieve the highest possible level of power protection in a fault-tolerant network. By connecting units in parallel, using the N+x system, a redundant system can be created. In this case all the UPSs equally share the load in the system during normal operation. In this way every possible single point of failure will be eliminated. This means that if one of the UPSs in the parallel system fails, the other(s) can still supply the load guaranteeing full protection without any interruption.

**Scalability:** To add power if needed without investments beforehand. Another reason for paralleling units is upgrading the power rating of the system. If e.g. a 5kVA **LanPro** is installed, the power rating can be upgraded to 10kVA by adding another 5kVA **LanPro** in parallel. This spread investment makes sure that you don't have to invest in advance, but only when you need to.

**GE Digital Energy's** unique RPA system has the following major advantages:

- **GE Digital Energy's** RPA offers true redundancy because not only the power electronics are redundant, but also the batteries, the bypass circuit and the control logic,
- The RPA system is an option: you don't have to buy it if you don't need it.



## 8 - Maintenance

### 8.1 General

When used properly, the UPS is virtually maintenance free other than keeping the air inlets/outlets free from dust.

### 8.2 Cooling fan

The expected operational life of the cooling fans is approximately 20.000 to 40.000 hours of continuous operation. A high ambient temperature will shorten this operational life.

### 8.3 Batteries

The service life of the battery is from 3 to 6 years, depending on the operating temperature and on the number of discharge cycles.

As a healthy battery is essential to the performance of the UPS, an automatic battery test is performed regularly to ensure failsafe operation (see section 5.4.1). When the condition of the battery is critical, the warning signal will be activated (buzzer 1x per 8 secs, and alarm message 'Replace battery', see 5.3.2). The batteries must be replaced as soon as possible. Please contact your dealer.

NOTE: under certain circumstances a *manual* battery test can result in a false alarm: please see section 5.4.2 'QUICK BATTERY TEST'.

Regular deep battery tests are advised in order to re-calibrate the capacity of aging batteries. See section 5.4.3 for more information.

**NOTE: All maintenance and service work, including battery replacement, should be performed by qualified service personnel.**

*For authorized service personnel only:*

*Never short the battery terminals. Shorting may cause the battery to burn. Avoid charging in a sealed container. Proper disposal of batteries is required: refer to your local codes for disposal requirements. Never dispose of batteries in a fire: they may explode. Never disassemble or reassemble batteries; their contents (electrolyte) may be extremely toxic. If exposed to electrolyte, wash immediately with plenty of water, if eye contact occurs flush with water and contact a physician.*

### 8.4 Safety



#### **CAUTION:**

*When the **LanPro** UPS is operating, all parts of the electronics are directly connected to the utility and high voltages are present on all internal parts, including the battery. Even after disconnection from the utility, all parts inside the **LanPro** UPS, including the battery, conduct dangerous voltages (except the RS232 output).*

For your safety, only authorized service personnel may remove the cabinet cover.

### 8.5 Storage

Always store the UPS in a dry location with the batteries in a fully charged state, storage temperature must be within -20 and +45°C. Storing the unit for a period exceeding 3 months can reduce the life of the batteries. To maintain their normal life expectancy, the batteries must be recharged periodically:

- if the storage temperature is within -20 and +30°C: every 3 months, for 24 hours,
- if the storage temperature is within -20 and +45°C: every month, for 24 hours.





## 9 - Troubleshooting

Whenever a malfunction occurs, first check external factors (e.g connections, temperature, humidity or load) to determine whether the problem is caused by the unit itself or by its environment. Subsequently check whether the MCB/switches on the rear panel (fig. 7, 7-8-9) are in 'on' position. Always check these external factors before concluding that your **LanPro** UPS is faulty.

The front screen will indicate the problem and solution (if the problem is due to environmental circumstances). If the solution is not shown on the screen, please contact your dealer.

During the self-test, performed immediately after start-up, the UPS may detect a system failure. In this case a message is displayed for 30 seconds before the self-test is repeated. If the faulty situation persists, please contact your dealer.

(One of) the following messages can be displayed:

SELFTEST FAILURE PCB POWER SUPPLY	One or more voltages of the internal power supply is (are) outside tolerance. Please contact your dealer.
SELFTEST FAILURE AC ON INPUT	An external AC voltage (not the UPSs output voltage) was detected on the output terminals. Please contact your dealer.
SELFTEST FAILURE INT.BATTERY FUSE	The internal battery fuse is defective. Please contact your dealer.
SELFTEST FAILURE EXT.BATTERY FUSE	The battery extension circuit breaker is in 'the off' position. Please switch it to 'the on' position.
SELFTEST FAILURE BATTERY CHARGER	Malfunction of the battery charger. Please contact your dealer.
SELFTEST FAILURE U <sub>ic</sub> TOO HIGH	Malfunction of the input circuit: voltage delivered is too high. Please contact your dealer.
SELFTEST FAILURE TEMP TOO HIGH	The temperature of (one of) the components is (still) too high. See section 5.3.2.
SELFTEST FAILURE U <sub>ba</sub> TOO LOW	The battery voltage is too low to allow start-up. Wait for a few hours, leave the UPS switched on.*
SELFTEST FAILURE U <sub>ic</sub> TOO LOW	Malfunction of input circuit: voltage delivered is too low. The batteries may be faulty or depleted. Wait for a few hours, leave the UPS switched on.*
SELFTEST FAILURE Q4 NOT OK	Hardware output voltage detection 'Q4' is active.

\* If absence of input power (utility failure, maintenance work) is expected to last longer than a few hours, switch off the UPS to save battery power. If the UPS input power is absent for several days and the UPS remains on under no-load conditions, the batteries can be discharged very deeply, resulting in a short battery life time.





## 10 - Specifications

<b>UPS Type</b>	:	<b>LP 3-11</b>	<b>LP 5-11</b>	<b>LP 6-11</b>	<b>LP 8-11</b>	<b>LP 10-11</b>
Output power (kVA/kW)	:	3/2.4	5/4	6/4.8	8/6.4	10/8
AC input voltage	:	220-240Vac				
Input frequency	:	50/60 Hz				
AC output voltage	:	230V				
Output frequency	:	50 or 60 Hz, std. 50 Hz; selectable on front				
System efficiency (full load)	:	88%				
Line input breaker (MCB, D-type)	:	32A	32A	32A	40A	50A
Bypass input breaker (MCB, D-type)	:	32A	32A	32A	40A	50A
Input/output connectors	:	terminals at rear of unit				

### INPUT

AC input voltage range	:	172 – 285 V				
at 100% load	:	147 - 285 V				
at 50% load	:	132 – 285 V				
at 25% load	:	40-70 Hz				
Input frequency range	:	sinusoidal				
Input current wave form	:	≥ 0.99				
Input power factor	:	16	28	28	40	50
Max. input current (A)	:	none				
Inrush current	:	380 V				
DC output voltage	:					

### BATTERY CHARGER

Characteristic	:	U/I-characteristic, constant current charging until float voltage, then constant voltage charging and boost charge mode for fast recharging of batteries				
DC input voltage range	:	350-450 V				
DC output voltage at 20 °C	:					
LP 3-11	:	float: 162.5 V boost: 177 V				
LP 5/6/8/10-11	:	float: 274 V boost: 295 V				
Output current limit (Adc)	:	2.0	2.0	2.0	3.6	3.6

### OUTPUT CONVERTER

Output power at pf. = 0.8, VA*	:	3000	5000	6000	8000	10000
Semiconductor	:	IGBT				
AC output voltage	:	230V ± 1% static resistive load				
	:	230V ± 2% measured crest load 2.5:1				
	:	230V ± 2% dynamic mean deviation over one half cycle for 100% of rated load applied or removed				
Typical overload (temp. dependent)	:	110% ≥ 20 minutes				
	:	130% ≥ 3.5 minutes				
	:	150% ≥ 2 minutes				
Output frequency	:	60 or 50 Hz selectable, ± 0.1%, unless synchronized with the mains				
Freq. tracking range	:	± 2/4/6% of nominal, user selectable				
Output wave form	:	sine wave				
Max. phase difference input-output	:	max 7°				
Harmonic distortion	:	2% max. with linear load				
Power factor range	:	Any lagging or leading power factor is permitted within the specified rating to pf. 0.5				
Output derating altitude	:	Till 1000m no derating				
	:	Above 1000m 12.5% per 1000m, max. 4000m				
Protection	:	Automatic shut down (or transfer to bypass, if bypass is available) in case of				
	:	- low/high DC voltage				
	:	- overtemperature				
	:	- overload / short circuit				

The output is protected against connection to the mains

\* according to EN 50091-1



**UPS Type** : **LP 3-11**    **LP 5-11**    **LP 6-11**    **LP 8-11**    **LP 10-11**

**AUTOMATIC BYPASS SWITCH**

The automatic switch provides transfer of the load to the mains voltage without any interruption of the supply. The transfer is initiated by a signal from the output converter protection circuit in case of an overload or high temperature. When the conditions return to normal the load is automatically transferred back to the output converter. The automatic bypass switch can be disabled by the end-user.

Bypass voltage limits : ±10% of nominal  
 Transfer transients : typically 2% mean deviation over one half cycle.  
 Frequency tracking range : ± 2/4/6% of nominal (user selectable)  
 Slew rate : max. 1Hz/sec or 5Hz/sec (user selectable)

**BATTERY**

Battery type : Sealed and maintenance free  
 Nominal voltage (V) / capacity (Ah) : 12/7    12/7    12/7    12/12    12/12  
 Number of batteries : 12    20    20    20    20  
 Capacity of standard battery set : 7 Ah    7Ah    7Ah    12Ah    12Ah  
 Battery recharge time : 1.5 - 3 hours for 80% capacity  
 Battery service life : up to 6 years (depending on operating conditions)  
 Battery discharging : self discharge current 0.35 mA  
 discharge end voltage of the battery depending on the actual load  
 10.5Vdc < 0.2 CA till 9.0 Vdc > 2 CA  
 When the LP-11 is in sleeping mode the inverter will be switched off, battery charger and rectifier are in operation

Runtime in minutes					
VA / Watts					
1000 / 800	:	30	60	60	120
2000 / 1600	:	15	40	40	60
3000 / 2400	:	10	18	18	40
5000 / 4000	:	-	10	10	22
6000 / 4800	:	-	-	8	17
8000 / 6400	:	-	-	-	11
10000 / 8000	:	-	-	-	8

**BATTERY EXTENSION PACKS**

Sheet steel cubicle : VSDA1  
 Dimensions (hxwx d, mm) : 537x313x590  
 Battery : 240Vdc/7Ah or 240Vdc/14Ah  
 Weight with battery : 70kg or 120kg (without batt: 20kg)

Battery pack A (voltage V / capacity Ah)	:	n.a.	240/7	240/7	240/7	240/7
Total capacity (Ah)	:	n.a.	14	14	19	19
Typical runtime, 100% / 50% load, min.	:	n.a.	25/60	21/50	22/50	16/39
Number of packs required	:	n.a.	1	1	1	1

Extension B (voltage V / capacity Ah)	:	n.a.	240/14	240/14	240/14	240/14
Total capacity (Ah)	:	n.a.	21	21	26	26
Typical runtime, 100% / 50% load, min.	:	n.a.	45/90	35/75	33/70	25/57
Number of packs required	:	n.a.	1	1	1	1

For more info see section 7.1

**ENCLOSURE**

Sheet steel cubicle : VSD1    VSD1    VSD1    VSD2    VSD2  
 Colour front : aluminum  
 Colour cabinet : RAL 9010 (white)  
 Protection : IP 20  
 Dimensions (hxwx d, mm) : 537x313x590    537x313x590    537x313x590    680x313x720    680x313x720  
 (height with castors)  
 Weight (with batteries) : 85kg    110kg    115kg    165kg    170kg

**GENERAL DESIGN CRITERIA**

Mechanical : IP20  
 Humidity : 95% non condensing  
 Safety : EN 50091-1; EN 60950; IEC 950  
 EMC : EN 50091-2  
 Surge capability : IEC 1000-4-5 (6kV 1.2/50µs, 3kA 8/20µs)



**ENVIRONMENT**

- Ambient temperature range : -10°C to +40°C
- Audible noise at 1 meter : 40 - 50 dB(A) with linear load (load and temperature dependent)
- Approvals : safety: EN 50091-1; IEC 950; pending  
EMC: EN 50091-2

**CONTROLS, INDICATORS AND ALARMS**

**Frontpanel with:**

- LED green : operation
- LED red : alarm
- LCD screen : 2 x 16 characters, shows system data, status messages, alarm messages, settings. Language is user selectable.
- Push-buttons : up, enter/reset, down
- Buzzer (resettable with push-button 'reset') : alarm

**Rear panel with:**

- MCB switch : UPS on/off
- MCB switch : Mains on/off
- MCB switch : Static Bypass on/off
- Manual bypass switch : for testing and maintenance purposes
- 9-pole female sub-D connector : RS232 interface  
contact interface: bypass active, battery low, general alarm, mains failure
- Option slot (middle) : optional plug-in SNMP Card or optional Relay Card
- Option slot (right) : optional plug-in RPA-Card (Redundant Parallel Architecture)
- Emergency shutdown connection
- Battery extension signal connection
- I/O terminals



### LanPro 3/5/6-11 installation drawing

Model	Heat dissipation				Dimensions			Weight	Air flow 100% load	Amb. temp.	Rel. humidity non-cond.	Altitude (max 4000m)	Branch protection slow	Input/output wiring		Minimum free space required			Bottom	
	100% load		50% load		h	w	d							front	side	rear	x	y		
LanPro	W	Btu/hr	W	Btu/hr	mm	mm	mm	kg	m <sup>3</sup> /hr	°C	%	m	A	mm <sup>2</sup>	AWG	mm	mm	mm	mm	mm
3-11	327	1116	211	720	537	313	590	85	330	-10-40	<95	<1000, derating 12.5% per 1000	16	4	12	100	50	200	184	448
5-11	545	1860	350	1195	537	313	590	110	330	-10-40	<95		25	6	10	100	50	200	184	448
6-11	655	2235	423	1445	537	313	590	115	330	-10-40	<95		25	6	10	100	50	200	184	448

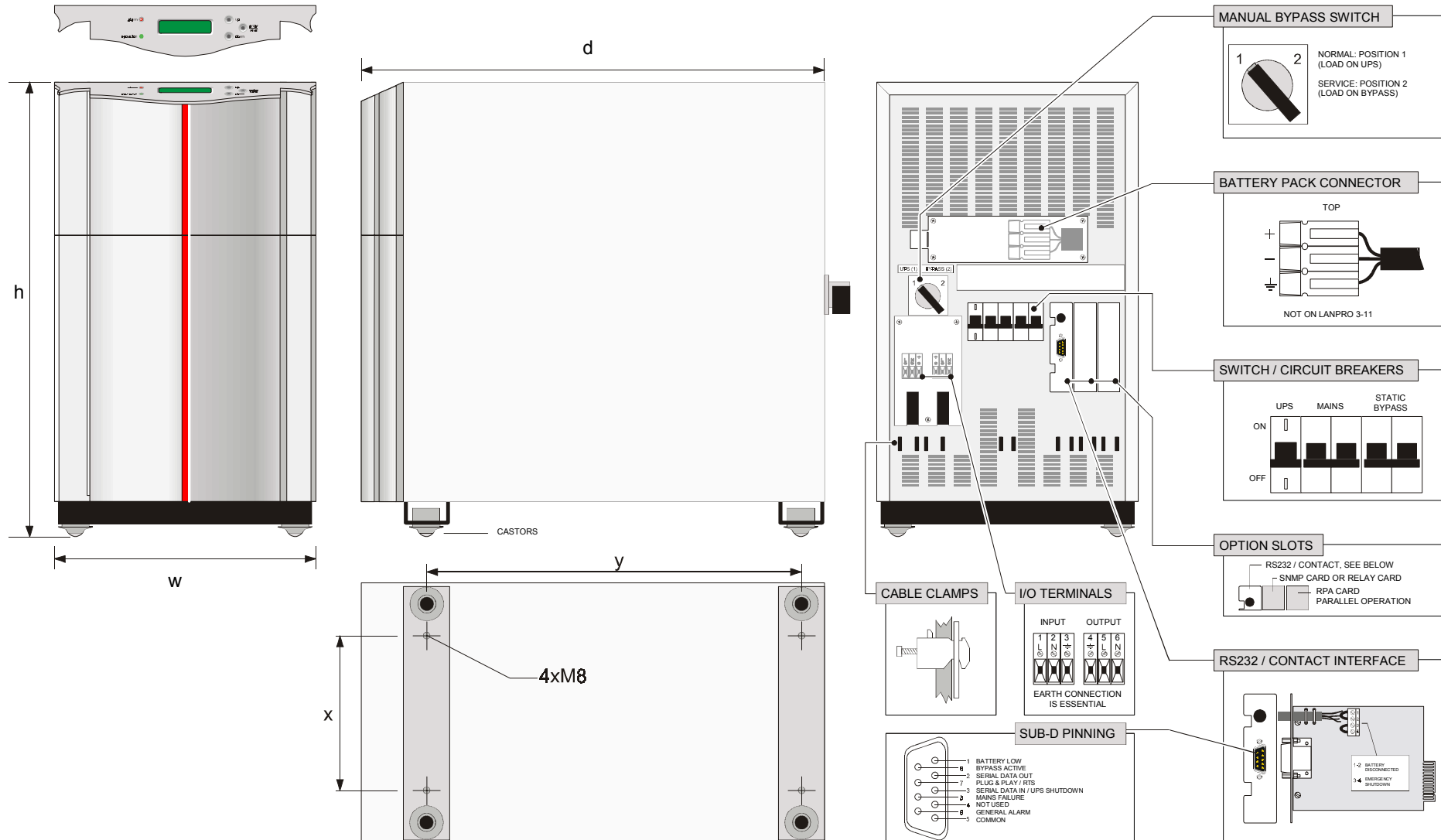



### LanPro 8/10-11 installation drawing

Model	Heat dissipation				Dimensions			Weight	Air flow 100% load	Amb. temp.	Rel. humidity non-cond.	Altitude (max 4000m)	Branch protection slow	Input/output wiring		Minimum free space required			Bottom	
	100% load		50% load		h	w	d							front	side	rear	x	y		
LanPro	W	Btu/hr	W	Btu/hr	mm	mm	mm	kg	m <sup>3</sup> /hr	°C	%	m	A	mm <sup>2</sup>	AWG	mm	mm	mm	mm	mm
8-11	872	2976	520	1774	680	313	720	165	660	-10-40	<95	<1000, derating 12.5% per 1000	50	10	8	100	50	200	184	578
10-11	988	3371	545	1860	680	313	720	170	660	-10-40	<95		50	10	8	100	50	200	184	578

